

## COMMERCIAL WALL MOUNT AUTOMATIC MOTION SENSOR FAUCET CHROME FINISH SPECS

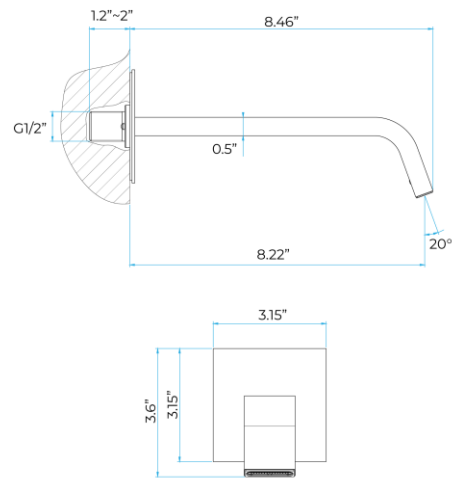

### Specs:

Power: DC:6V(4AA alkaline battery)

AC:220V-240V; 50/60HZ

Water Consumption: 0.05Mpa-0.7Mpa

Detection Zone: 16-32 cm or adjustable

Motor valve lifespan: up to 500000  
flushes

Battery lifespan: 100000 cycles

Power consumption: DC 0.2mW; Ac 2W –  
5W

Inductive Opening Time: < 1 second

Inductive Closing Time: < 2 second

Dia.of inlet / outlet pipe: G1/2"

Flux:  $\geq 0.07L/S$

Temperature: 0.1-50°C

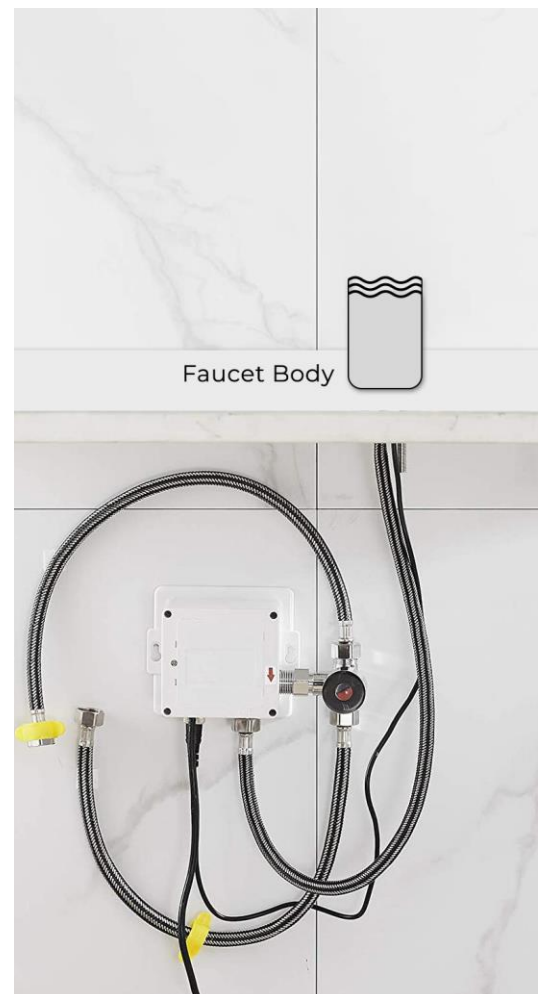

### Other Details

[Product Details](#)